

Overhead Facilities Responsibilities – Who Owns What?

The Wallingford Electric Division owns and is responsible for the following:

- The utility pole.
- The wires from the pole to the home, up to the point of connection.
- The electric meter.

The customer owns and is responsible for the following:

- The wires from the connection point to the meter box. These wires are usually inside a metal or plastic conduit.
- Any conduit containing wire that runs up the side of the home.
- The meter box.

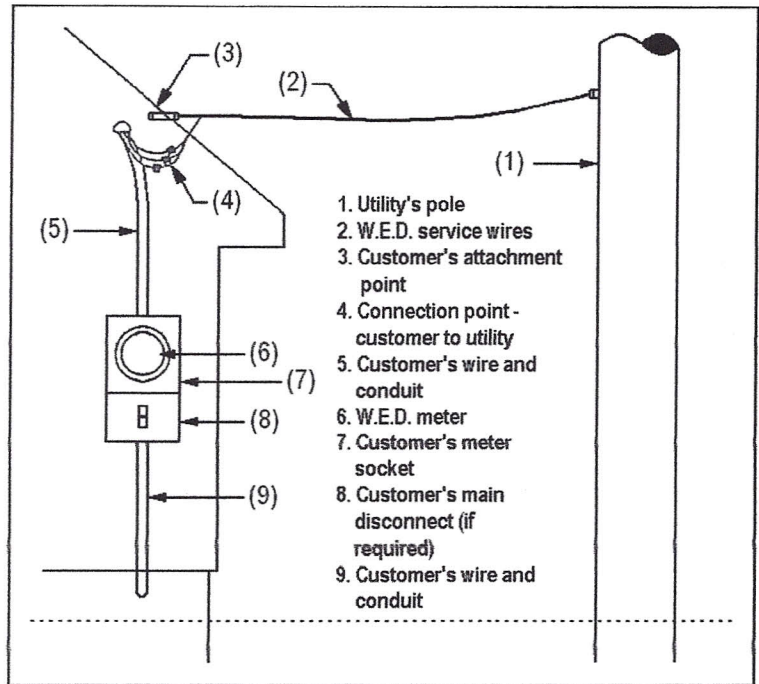

Service cannot be restored if any of the customer's equipment is damaged. The customer is responsible for contacting a licensed electrician to repair this damage and to contact the Town's Electrical Inspector to perform an inspection. The Wallingford Electric Division will not restore power until an inspection has been done.

All requests for inspections should be made to the Wallingford Building Department at (203) 294-2095 between 8:30 AM and 5:00 PM. Outside these hours, a formal signed letter on company letterhead from a licensed E-1 electrician may be faxed to the Wallingford Electric Division at (203) 294-2267 and should include Contractor's name, E-1 license number and a language that states that the service is safe to re-energize.